

# Heavy Duty 6 & 10

## CONDENSATE REMOVAL PUMP

With an impressive flow rate, these robust and reliable Heavy Duty pumps are perfect for the rapid removal of large quantities of condensate water.

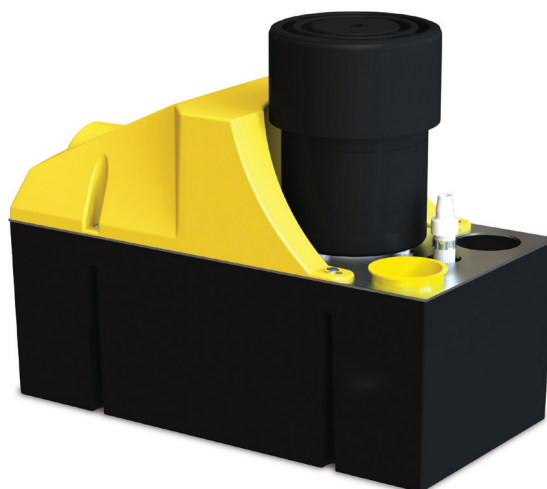

HD6: 900L/h max. flow  
HD10: 1070L/h max. flow



HD6: 6m max. rec. head  
(flow rate 180L/h)  
HD10: 9m max. rec. head  
(flow rate 100L/h)

### KEY FEATURES

- High flow rate
- Non return valve
- Easy installation
- 4 litre tank capacity

### SUITABILITY

- HD6: Up to 1200kW / 4m Btu/h
  - HD10: Up to 1460kW / 4.9m Btu/h
  - Dehumidifiers; Air handling units (AHUs)
- ✓ **Perfect for...** Large volumes of water

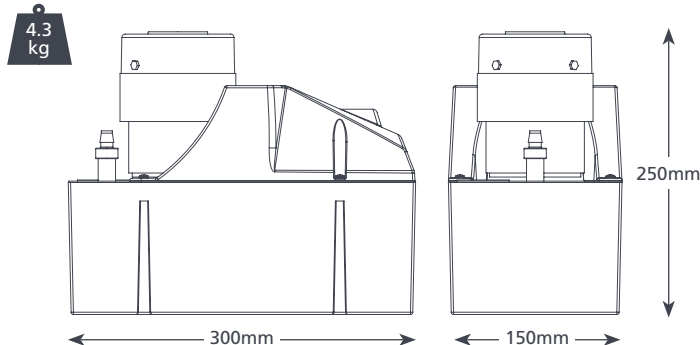
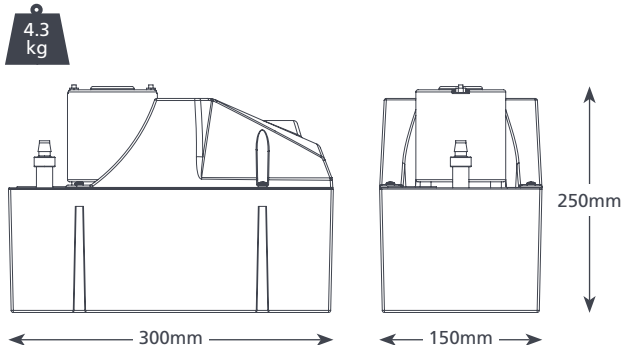

HEAVY DUTY 6 & 10 @ 230 VAC 50Hz	
Max. flow	HD6: 900L/h, HD10: 1070L/h
Max. rec. head	HD6: 6m, HD10: 9m
Tank capacity	4L
dB(A) @ 1m	HD6: 60, HD10: 64
Power supply	HD6: 230 VAC, 0.45A, 50Hz HD10: 230 VAC, 0.45A, 50Hz
Rated	HD6: Non continuous HD10: Continuous
Class	I appliance
Max. unit output	HD6: 1200kW / 4m Btu/h HD10: 1460kW / 4.9m Btu/h
Max. water temp	40°C / 104°F
Inlet/outlet	x2 40mm in, 10mm out
IP Protection	IP20
Safety switch	3.0A Normally closed

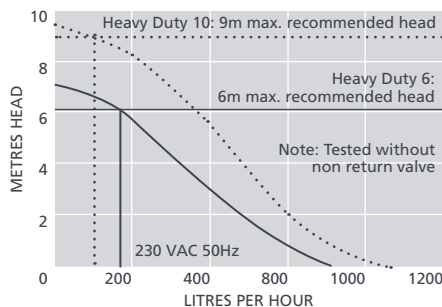

### SUGGESTED XTRA ACCESSORIES

Description	Part No.
Pipe to Pipe connector 21mm-40mm	FP2018
Tube To Soil Stack Adaptor	FP2038
Vinyl Tube Braided 3/8" (10mm)	AX5101



For more installation accessories take a look at our Aspen Xtra range

### HEAVY DUTY 6 & 10 OPTIONS

Heavy Duty 6	FP2074/2
Heavy Duty 10	FP2066/2

### IN THE BOX

Heavy Duty 6 or 10 pump • 2m power cable  
• Install manual



Download manual at [aspenpumps.com](http://aspenpumps.com)